

Surface Mount, High Power

Bi-Directional Coupler SYDC-10-52VHP+

50Ω 10 dB Coupling 30 to 512 MHz 35 Watt

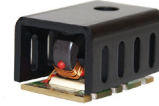

CASE STYLE: PD1647-1

The Big Deal

- High power handling, 35W
- Very low mainline loss, 0.5 dB
- Excellent VSWR, 1.18

Product Overview

Mini-Circuits' SYDC-10-52VHP+ surface mount bi-directional coupler provides high power handling up to 35W and low mainline loss of 0.5 dB for applications from 30 to 512 MHz. This model features a unique heat sinking design that enables reliable operation at high power without overheating, making it an ideal choice for systems where high power capability and small size are desired. The coupler features core and wire construction mounted on an 8 -lead printed laminate base with wraparound terminations for excellent solderability. The unit measures 0.75 x 0.52 x 0.43", accommodating dense circuit board layouts.

Key Features

Feature	Advantages
High power handling <ul style="list-style-type: none">• 35W, 2.0 VSWR max.• 10W, output open or short	Usable in many systems with high-power requirements
Low mainline loss, 0.5 dB	Provides excellent through-path signal power transmission.
Good directivity, up to 22 dB	High directivity allows accurate signal sampling through the coupled port with minimal measurement error.
Excellent return loss, up to 25 dB (input/output/coupling)	Provides excellent matching in 50Ω systems with minimal signal reflection.
Small size, 0.75 x 0.52 x 0.43"	Provides high power capability while saving space in systems with tight layouts.

Notes

- A. Performance and quality attributes and conditions not expressly stated in this specification document are intended to be excluded and do not form a part of this specification document.
B. Electrical specifications and performance data contained in this specification document are based on Mini-Circuit's applicable established test performance criteria and measurement instructions.
C. The parts covered by this specification document are subject to Mini-Circuits standard limited warranty and terms and conditions (collectively, "Standard Terms"); Purchasers of this part are entitled to the rights and benefits contained therein. For a full statement of the Standard Terms and the exclusive rights and remedies thereunder, please visit Mini-Circuits' website at www.minicircuits.com/MCLStore/terms.jsp



Surface Mount, High Power Bi-Directional Coupler

SYDC-10-52VHP+

50Ω 10 dB Coupling 30 to 512 MHz 35 Watt



CASE STYLE: PD1647-1**

**This model is not intended for pick & place use. Please contact Applications Dept. for assistance

+RoHS Compliant

The +Suffix identifies RoHS Compliance. See our web site for RoHS Compliance methodologies and qualifications

Maximum Ratings

Operating Temperature -40°C to 65°C Case*

Storage Temperature -55°C to 100°C

* Case temperature is defined as temperature on ground leads. Permanent damage may occur if any of these limits are exceeded.

Pad Connections

INPUT	1
OUTPUT	8
COUPLED (FORWARD)	4
COUPLED (REVERSE)	5
GROUND	2,3,6,7

Outline Drawing

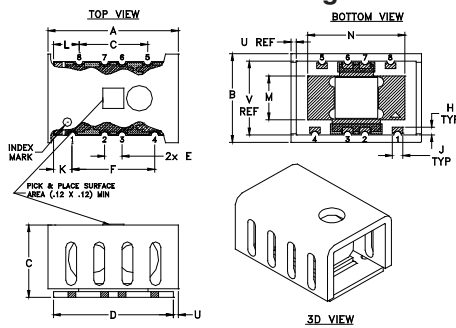

PCB Land Pattern

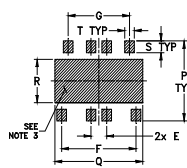

Suggested Layout,
Tolerance to be within ±.002

Outline Dimensions (inch)

A	B	C	D	E	F	G	H	J	K	L	M	N	P	Q	R	S	T	U	V	wt
.750	.520	.43	.690	.100	.476	.394	.045	.060	.107	.148	.257	.560	.475	.561	.258	.069	.061	.03	.433	grams
19.05	13.21	10.92	17.53	2.54	12.09	10.01	1.14	1.52	2.72	3.76	6.53	14.22	12.07	14.25	6.55	1.75	1.55	0.76	11.00	3.00

Demo Board MCL P/N: TB-630+ Suggested PCB Layout (PL-351)

Refer to Application Note: [AN-00-017](#)

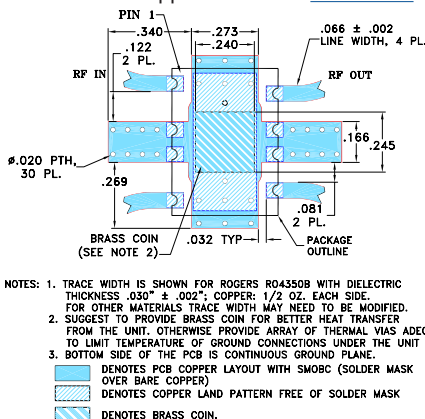

Features

- high power, 35 W max. with output load VSWR 2.0 max
- high power, 10 W max. with output open or short
- low mainline loss, 0.5 dB typ.
- good VSWR, 1.18 typ.

Applications

- military mobile

Electrical Specifications at 25°C

Parameter	Condition (MHz)	Min.	Typ.	Max.	Unit
Frequency Range		30	—	512	MHz
Mainline Loss ¹ (above theoretical 0.5 dB)	30	—	0.3	0.5	dB
	450	—	0.45	0.8	
	512	—	0.65	0.9	
Coupling	30-512	—	10±0.8	—	dB
Coupling Flatness(±)	30-512	—	0.4	0.6	dB
Directivity	30-250	18	22	—	dB
	250-450	16	20	—	
	450-512	14	18	—	
Return Loss (Input)	30-250	18	20	—	dB
	250-450	20	25	—	
	450-512	17	23	—	
Return Loss (Output)	30-250	18	20	—	dB
	250-450	20	26	—	
	450-512	18	25	—	
Return Loss (Coupling)	30-250	18	20	—	dB
	250-450	16	20	—	
	450-512	15	18	—	
Input Power ¹	30-512	—	—	35	W

1. The user must provide adequate means of heat removal to limit the temperature of ground connections under the PCB to 65°C, in order to ensure proper performance. At 25°C ambient temperature this requires thermal resistance of the user's PC board heat sink to be 3.5°C/W.

Typical Performance Data

Frequency (MHz)	Mainline Loss (dB)		Coupling (dB)		Directivity (dB)			Return Loss (dB)	
	In-Out	In-Cpl Fwd	In-Cpl Rev	Out-Cpl Rev	In-Cpl Fwd	In	Out	Cpl Fwd	Cpl Rev
30.0	0.62	9.8	9.8	22.4	24.2	20.8	20.7	21.0	20.6
50.0	0.75	9.8	10.0	22.7	24.0	22.3	25.9	22.5	25.4
100.0	0.79	9.9	10.0	22.2	24.1	22.9	28.4	23.2	27.4
200.0	0.82	9.8	9.9	21.5	24.5	24.5	29.4	25.3	27.9
250.0	0.84	9.7	9.8	21.1	24.7	25.7	30.2	26.1	28.0
300.0	0.88	9.6	9.7	20.8	25.2	26.5	31.0	27.0	28.1
350.0	0.92	9.5	9.6	20.3	25.8	27.8	32.3	27.2	27.8
450.0	1.03	9.2	9.3	19.6	26.9	29.6	35.2	25.3	25.6
500.0	1.10	9.1	9.1	19.2	27.2	29.8	35.4	23.6	23.8
512.0	1.12	9.0	9.1	19.1	27.2	29.7	35.1	23.2	23.4

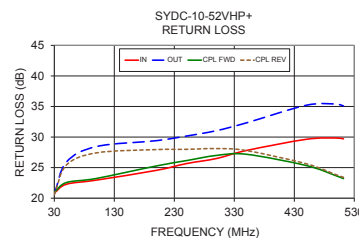
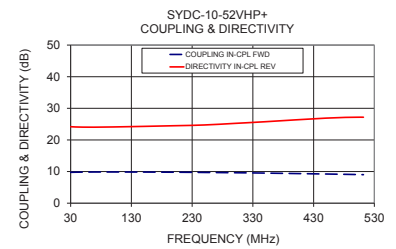
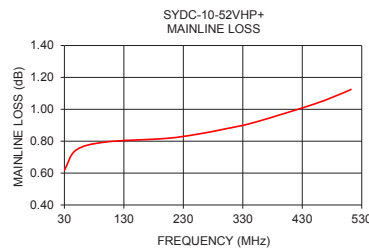

Electrical Schematic

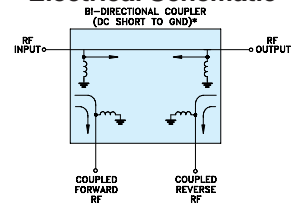

* ELECTRICAL SCHEMATIC IS FOR BI-DIRECTIONAL COUPLER WITH INTERNAL TRANSFORMERS THAT ROUTES DC FROM RF PORTS TO GROUND.

Notes

- Performance and quality attributes and conditions not expressly stated in this specification document are intended to be excluded and do not form a part of this specification document.
- Electrical specifications and performance data contained in this specification document are based on Mini-Circuit's applicable established test performance criteria and measurement instructions.
- The parts covered by this specification document are subject to Mini-Circuit's standard limited warranty and terms and conditions (collectively, "Standard Terms"); Purchasers of this part are entitled to the rights and benefits contained therein. For a full statement of the Standard Terms and the exclusive rights and remedies thereunder, please visit Mini-Circuit's website at www.minicircuits.com/WCLStore/terms.jsp



www.minicircuits.com P.O. Box 350166, Brooklyn, NY 11235-0003 (718) 934-4500 sales@minicircuits.com

REV. A
M159306
ED-16032801/1
SYDC-10-52VHP+
WP/CP/AM
161214
Page 2 of 2