

# Surface Mount Bandpass Filter

## SYBP-2640+

50Ω 2500 to 2780 MHz



CASE STYLE: TT1423  
PRICE: \$9.95 ea. QTY (10)

### Features

- High power handling
- Small size
- Temperature stable
- Excellent rejection

### Applications

- Satellite
- Mobile
- Lab use

### Electrical Specifications at 25°C

Parameter	F#	Frequency (MHz)	Min.	Typ.	Max.	Unit	
Pass Band	Center Frequency	—	—	2640	—	MHz	
	Insertion Loss	F1-F2	2500 - 2780	—	2.3	2.9	dB
	VSWR	F1-F2	2500 - 2780	—	2.0	2.5	:1
Stop Band, Lower	Insertion Loss	DC-F3	DC - 1780	20	23	—	dB
	VSWR	DC-F3	DC - 1780	—	15	—	:1
Stop Band, Upper	Insertion Loss	F4-F5	3800 - 6040	20	30	—	dB
	VSWR	F4-F5	3800 - 6040	—	10	—	:1

### Maximum Ratings

Operating Temperature	-40°C to 85°C
Storage Temperature	-55°C to 100°C
RF Power Input	7W* max. at 25°C

\*Passband rating, derate linearly to 3W at 85°C ambient  
Permanent damage may occur if any of these limits are exceeded.

### Functional Schematic

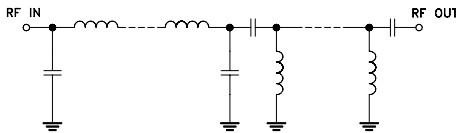

### Typical Performance Data at 25°C

Frequency (MHz)	Insertion Loss (dB)	VSWR (:1)
10.00	71.24	66.50
100.00	54.17	47.56
500.00	44.39	34.98
1000.00	58.56	34.73
1520.00	36.11	28.34
1600.00	33.17	26.66
1780.00	24.59	21.89
2000.00	12.23	11.50
2500.00	2.33	1.87
2780.00	2.29	1.80
3000.00	3.22	2.54
3720.00	26.76	8.04
4000.00	31.36	8.73
5000.00	27.09	11.73
6040.00	35.70	7.78

### Typical Frequency Response

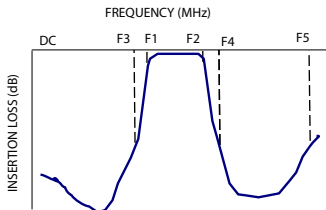

+ RoHS compliant in accordance with EU Directive (2002/95/EC)

The +Suffix has been added in order to identify RoHS Compliance. See our web site for RoHS Compliance methodologies and qualifications.

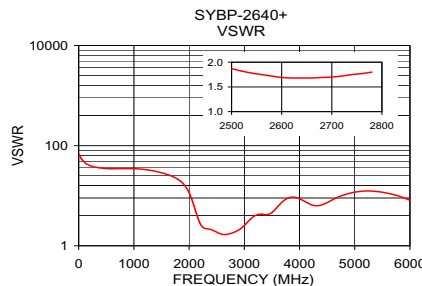
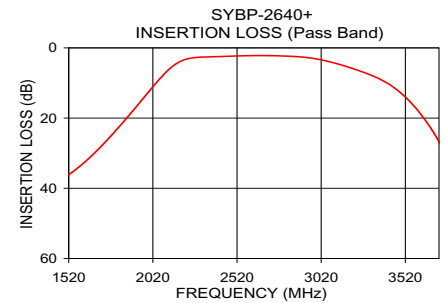
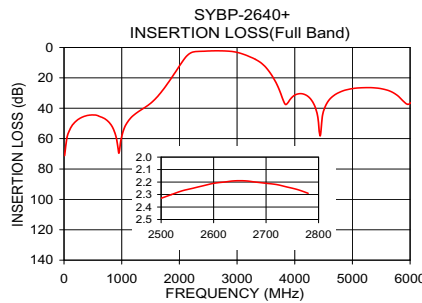

**Mini-Circuits®**  
ISO 9001 ISO 14001 AS 9100 CERTIFIED

For detailed performance specs & shopping online see web site

P.O. Box 350166, Brooklyn, New York 11235-0003 (718) 934-4500 Fax (718) 332-4661 The Design Engineers Search Engine Provides ACTUAL Data Instantly at [minicircuits.com](http://minicircuits.com)

IFIRF MICROWAVE COMPONENTS

Notes: 1. Performance and quality attributes and conditions not expressly stated in this specification sheet are intended to be excluded and do not form a part of this specification sheet. 2. Electrical specifications and performance data contained herein are based on Mini-Circuit's applicable established test performance criteria and measurement instructions. 3. The parts covered by this specification sheet are subject to Mini-Circuits standard limited warranty and terms and conditions (collectively, "Standard Terms"); Purchasers of this part are entitled to the rights and benefits contained therein. For a full statement of the Standard Terms and the exclusive rights and remedies thereunder, please visit Mini-Circuits' website at [www.minicircuits.com/MCLStore/terms.jsp](http://www.minicircuits.com/MCLStore/terms.jsp).

REV. OR  
M128407  
ED-13680/18  
SYBP-2640+  
AD/CP/AM  
110322  
Page 2 of 3



## Pin Connections

RF IN	4
RF OUT	6
GROUND	1,2,3,5

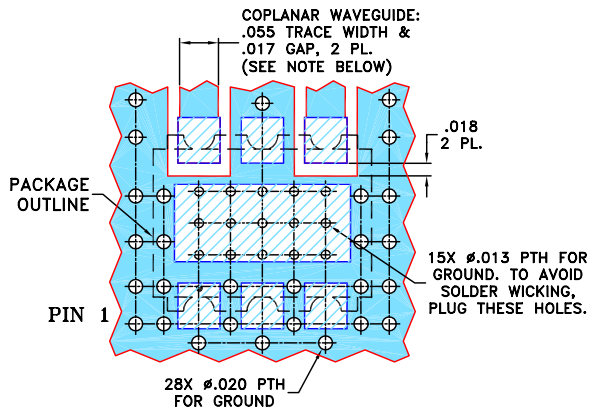
Demo Board MCL P/N: TB-517+  
Suggested PCB Layout (PL-308)



### NOTES:

- COPLANAR WAVEGUIDE PARAMETERS ARE SHOWN FOR ROGERS R04350B WITH THICKNESS  $.030'' \pm .002''$ ; COPPER: 1/2 OZ. EACH SIDE. FOR OTHER MATERIALS TRACE WIDTH AND GAP MAY NEED TO BE MODIFIED.
  - BOTTOM SIDE OF THE PCB IS CONTINUOUS GROUND PLANE.
-  DENOTES PCB COPPER LAYOUT WITH SMOBC (SOLDER MASK OVER BARE COPPER)
-  DENOTES COPPER LAND PATTERN FREE OF SOLDER MASK

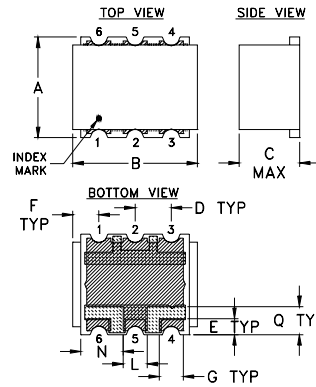

## Outline Drawing

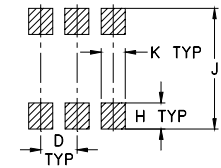

### PCB Land Pattern



Suggested Layout,  
Tolerance to be within  $\pm .002$

-  METALLIZATION
-  SOLDER RESIST

## Outline Dimensions (inch)

A	B	C	D	E	F	G	H
.25	.31	.15	.090	.040	.065	.060	.065
6.35	7.87	3.81	2.29	1.02	1.65	1.52	1.65
J	K	L	N	Q	wt.		
.300	.060	.060	.105	.070	grams		
7.62	1.52	1.52	2.67	1.78	0.50		